

No.	Drawing / PN. No.	Description
1-1	DL36TC	Cap -Top Cover
1-2	N/A	Self Tapping 2.5 x 10mm - Pan Pozi self coloured screws
1-3	N/A	Upper lamp holder for LED fixing bar
1-4	N/A	Waterproof ring gasket for LED fixing bar
1-5	N/A	Waterproof O-ring gasket - diffuser seal
1-6	N/A	Diffuser - Opal
1-7	N/A	Heat sink - LED PCBA extrusion
1-8	N/A	LED Linear Strip board - 2-3W per board
1-9	N/A	LED Ring PCB connector
1-10	N/A	Diffusor compression ring
1-11	N/A	Waterproof o-ring gasket -diffusor compressor ring seal
1-12	LED36WULB	Top Cover base moulding
1-13	N/A	Self Tapping M4 x 16mm - Pan Pozi Plastech screws - Black
1-14	N/A	Grommet- Cable entry bulkhead grommet
1-15	N/A	Lower lamp holder for LED fixing bar
1-16	N/A	Self Tapping M3 x 6mm - Pan Pozi Plastech screws - Diffusor retention screw

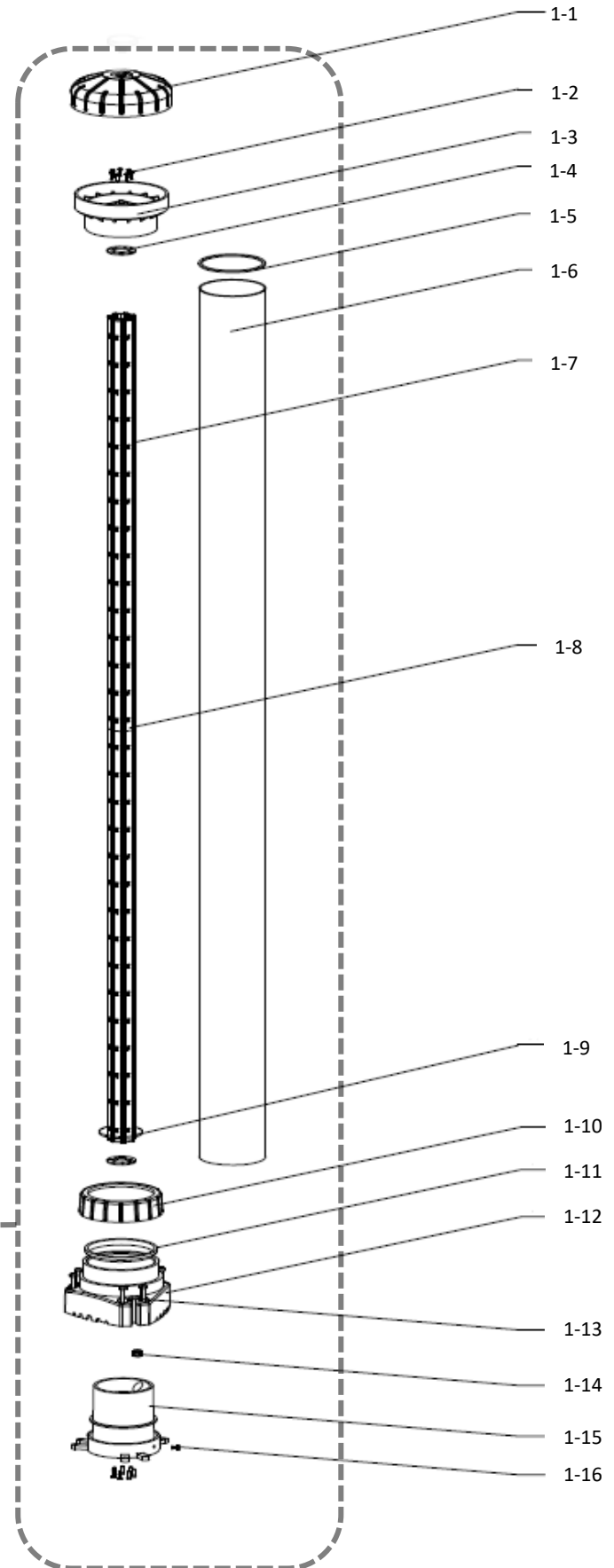

Part No: **DL36LIGHTHEAD**
Complete Light Head

Description: Delta Light 36W LED
 Light head – Compatible with all
 variants of Delta Lights

Part No: **DL36REBASE**
Complete Rechargeable Base Only

DL36R (Complete unit)

Description: Delta Light 36W Battery Rechargeable base

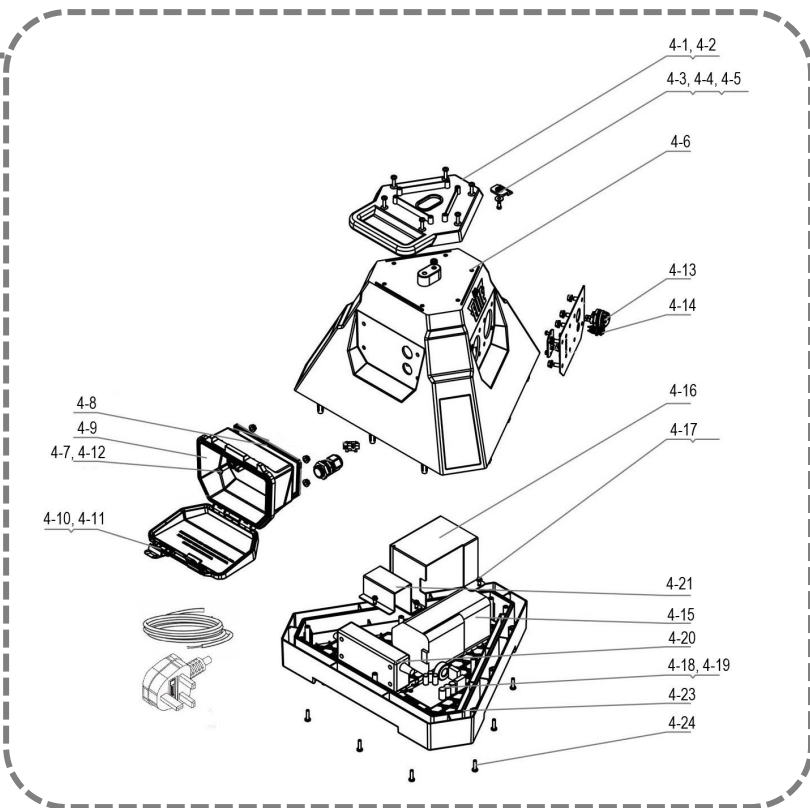

No.	Drawing / PN. No.	Description	No.	Drawing / PN. No.	Description
4-1	N/A	Self Tapping M4 x 16mm - Pan Pozi Plastech screws - Base handle plate screws	4-13	DL36MS	On / Off switch
4-2	DL36RBHPR	Base handle plate - Red	4-14	DL36RS	Light output – power select switch
4-3	DL36CS	Cable Management Strap	4-15	DL36RB	Battery 14.4V 18.2 Ah
4-4	N/A	Self Tapping Screw M4 x 8mm - Cable Management Strap	4-16	DL36RBRP	Battery retaining plate
4-5	N/A	M4 Washer - Cable Management Strap	4-17	N/A	Battery retaining plate Screws – M3 x 8mm self tapping
4-6	DL36BH	Base Housing	4-18	DL36RD	36W LED Driver - Constant Current – Rechargeable
4-7	N/A	Charger Box fixings – Nyloc Nut - M4	4-19	N/A	Self Tapping Screw M3 x 8mm - LED Driver retaining Screws
4-8	DL36RCHG	Charger connection box gasket	4-20	DL36RMC	Battery Charger – 16.8V 3.0A
4-9	DL36RCH	Charger connection box – back box	4-21	DL36RBCRP	Battery Charger retaining plate
4-10	DL36RCHL	Charger connection box – Lid	4-22	N/A	Battery Charger retaining plate fixings – M3 x 8mm self tapping
4-11	DL36RCHC	Charger connection box – Lid catches	4-23	DL36B	Base Footplate
4-12	N/A	Charger connection box – Fixing bolts - Machine Screws - M4 x 20mm BZP	4-24	N/A	Base Footplate fixing screws - Self Tapping M4 x 16mm - Pan Pozi Plastech screws -