



USER MANUAL



Master Dual Voltage Direct Oil-Fired Heater

**Product Code:
B100DV**



Serial Number Range:

From:

To:

Year Of Manufacture:

***Please note, when ordering online via our website if the part number is not recognised, please Email spares@hscgroupuk.co.uk or Telephone 0115 946 1988**

KEEP THIS BOOKLET FOR FUTURE REFERENCE

Nottingham: 0115 946 1988 • London: 0208 830 3333 ✉ Nottingham: sales@hscgroupuk.co.uk • London: sean@hscgroupuk.co.uk 🌐 www.hscgroupuk.co.uk

The Hire Supply Company Terms & Conditions Apply At All Time E&OE



MASTEER[®]
CLIMATE SOLUTIONS
MCS

USER AND MAINTENANCE BOOK

LIBRETTO USO E MANUTENZIONE



B 35CED DV - B 70CED DV
B 100CED DV - B 150CED DV

FIGURES - FIGURE

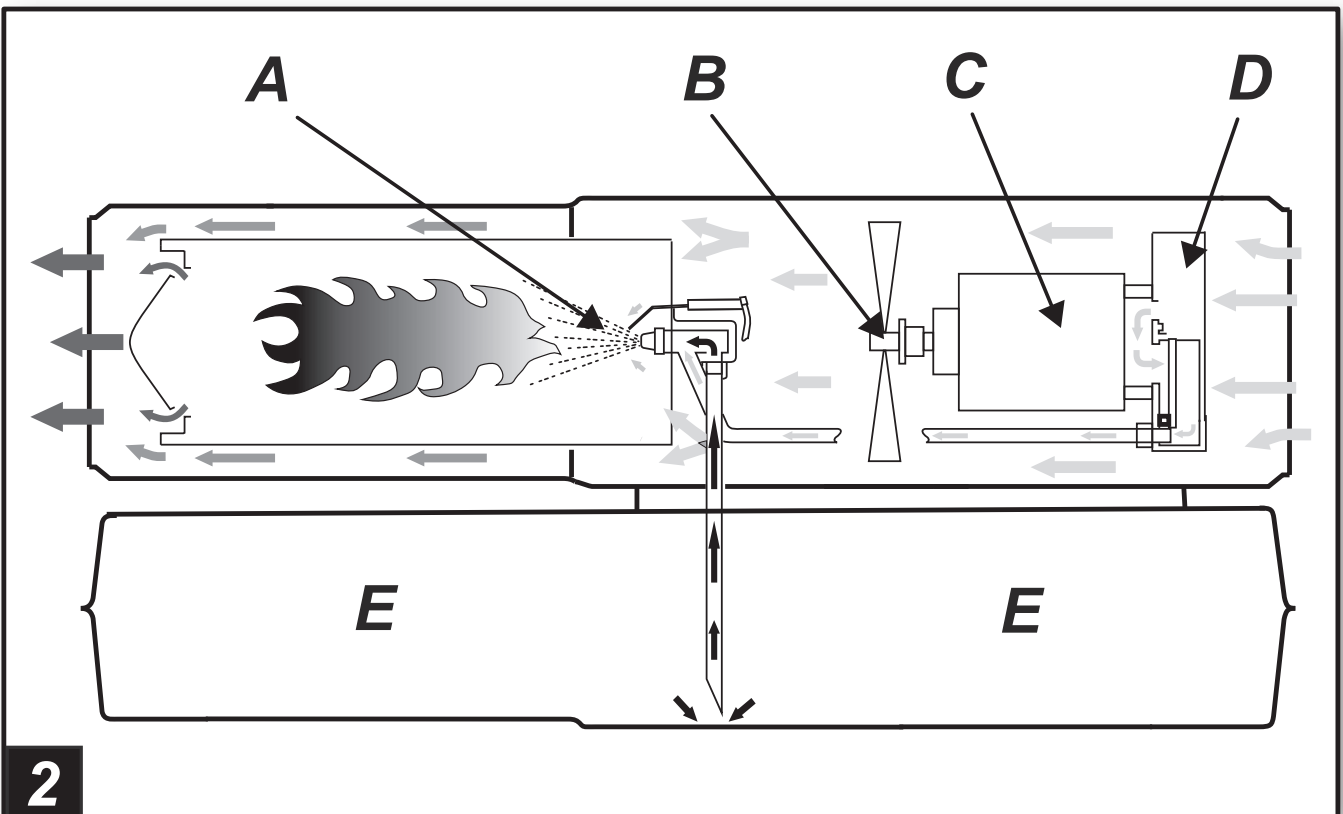
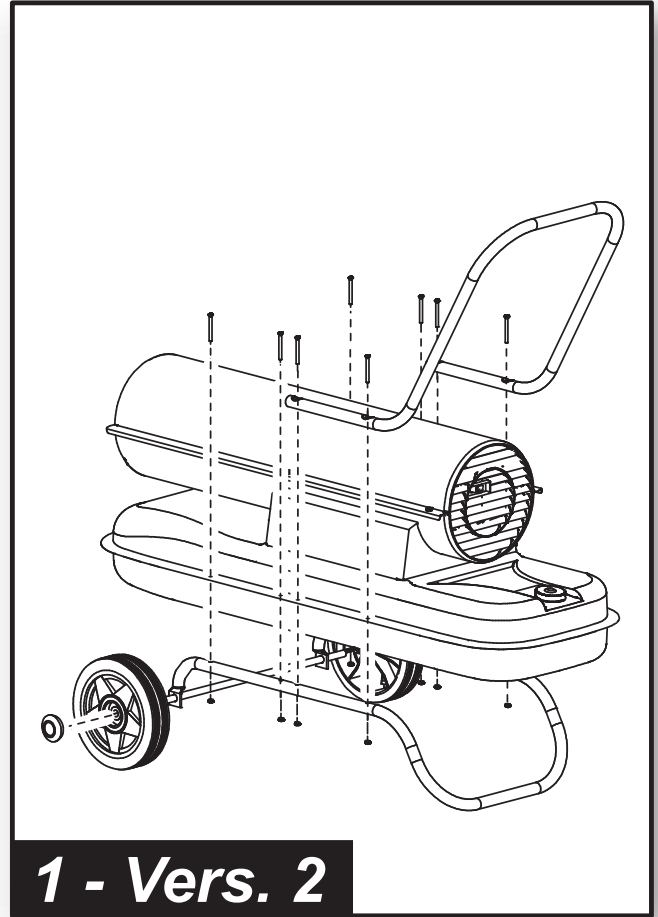
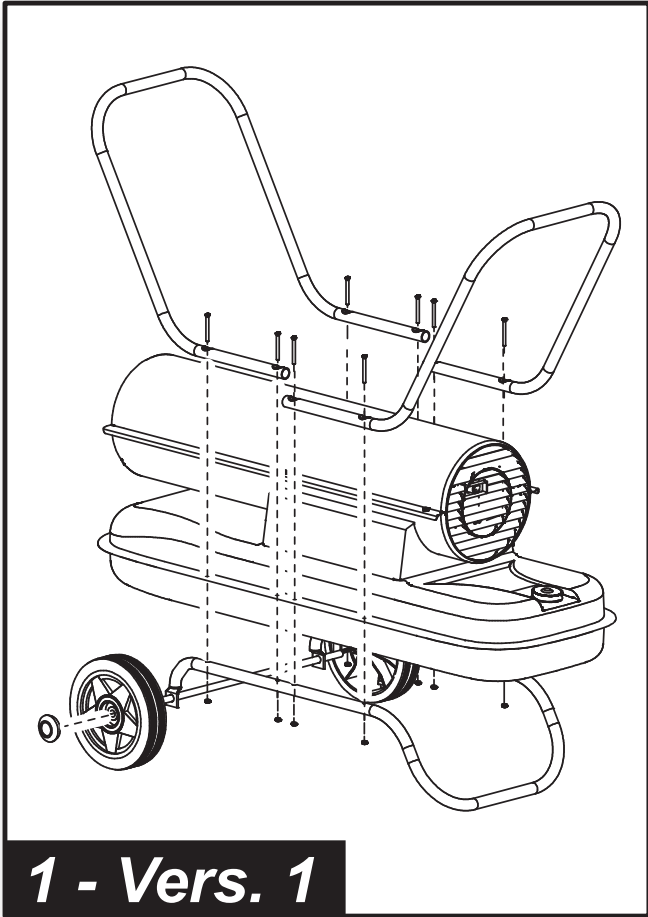

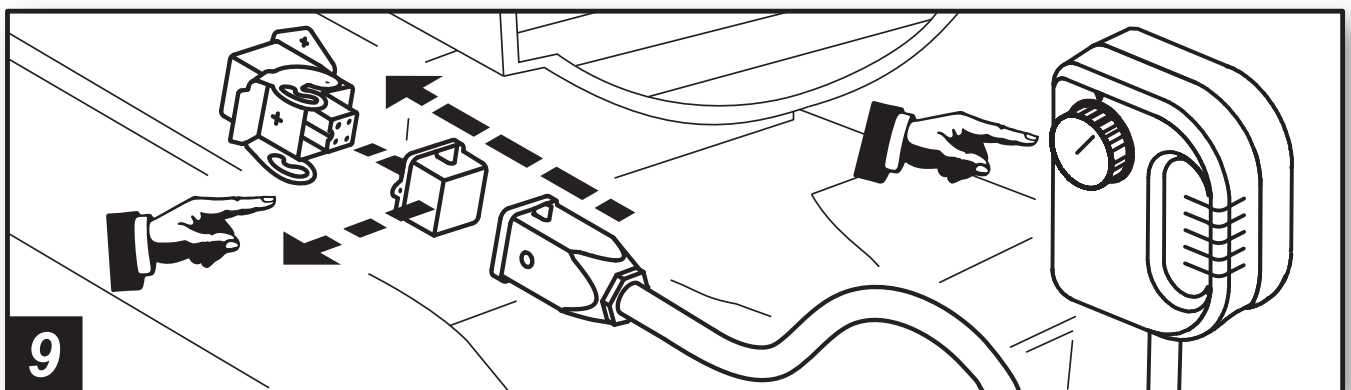
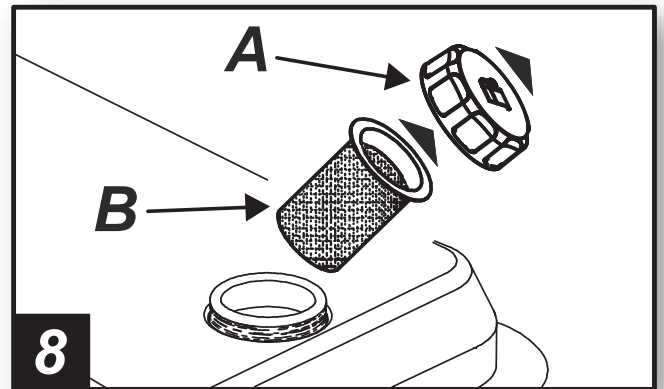
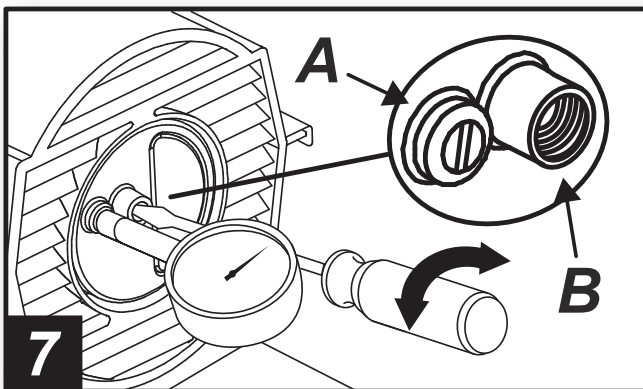
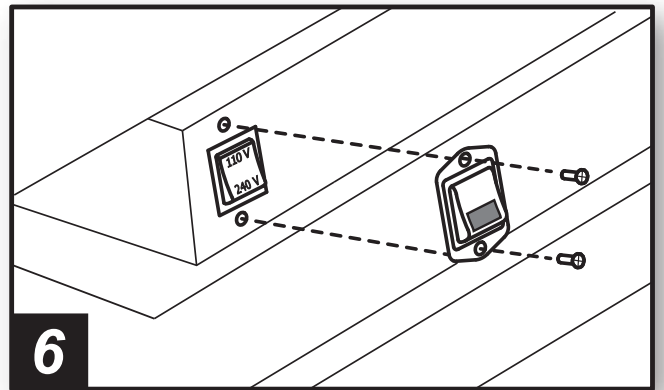
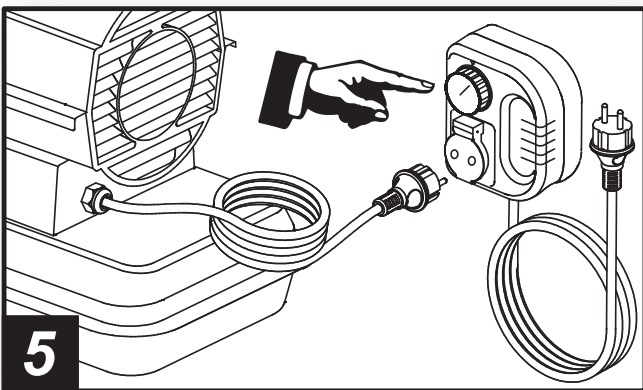
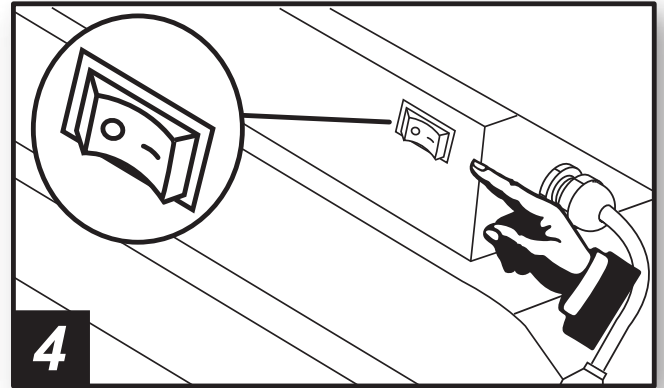
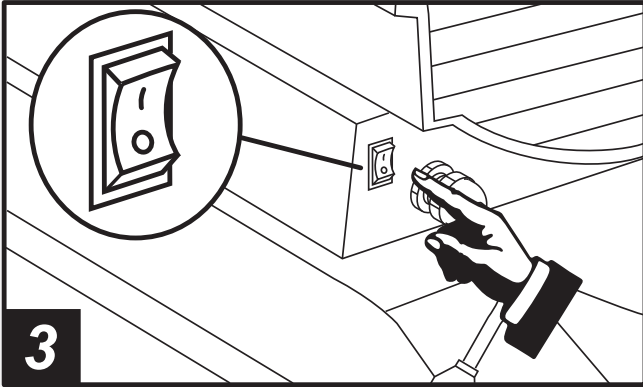

FIGURES - FIGURE



IMPORTANT: READ AND UNDERSTAND THIS OPERATIONAL MANUAL BEFORE PERFORMING ASSEMBLY, COMMISSIONING OR MAINTENANCE ON THIS HEATER. INCORRECT USE OF THE HEATER CAN CAUSE SERIOUS INJURY. KEEP THIS MANUAL FOR FURTHER REFERENCE.

1. INFORMATION REGARDING SAFETY WARNINGS

 **IMPORTANT:** This appliance is not intended for use by persons (including children) with reduced physical, sensory and mental capacities or with lack of experience or knowledge unless supervised by a person responsible for their safety. Children must be supervised to make sure they neither do nor play with the appliance.

 **DANGER:** Suffocation by carbon monoxide can be fatal.

The first symptoms of suffocation by carbon monoxide are similar to those of flu with headache, light-headedness and/or nausea. These symptoms could be caused by the faulty functioning of the heater. **IF THESE SYMPTOMS SHOULD OCCUR, DO OUTDOORS IMMEDIATELY and have the heater repaired by a technical after-sales centre.**

1.1 TOPPING-UP:

- ▶ **1.1.1.** Staff in charge of top-up must be qualified and understand the manufacturer's instructions and the Standards in force regarding safe top-up of the heaters.
- ▶ **1.1.2.** Only use the type of fuel expressly specified on the heater identification plate.
- ▶ **1.1.3.** Before topping-up, switch the heater off and wait for it to cool down.
- ▶ **1.1.4.** The fuel storage tanks must be in a separate structure.
- ▶ **1.1.5.** All fuel tanks must be at a minimum safety distance from the heater, according to the Standards in force.
- ▶ **1.1.6.** The fuel must be kept in rooms where the floor does not allow penetration and dripping of the same onto

flames below, which can cause ignition.

- ▶ **1.1.7.** The fuel must be stored in compliance with the Standard in force.

1.2 SAFETY:

- ▶ **1.2.1.** Never use the heater in rooms where petrol, solvents for paints or other highly inflammable vapours are present.
- ▶ **1.2.2.** During use of the heater, follow all local regulations and the Standard in force.
- ▶ **1.2.3.** The heaters in proximity of tarpaulin, curtains or other similar covering materials, must be situated at a safe distance from the same. It is advised to use fire-proof covering material.
- ▶ **1.2.4.** Only use in well-ventilated areas. Set-up a suitable opening according to the Laws in force, with the purpose of introducing fresh air from outdoors.
- ▶ **1.2.5.** Power the heater only with current that has voltage and frequency specified on the heater identification plate.
- ▶ **1.2.6.** Only use extensions with three wires, appropriately connected to earth.
- ▶ **1.2.7.** Minimum safety distances recommended, running between the heater and the inflammable substances are: front output = 2.5 m; side, at top and on rear = 1.5 m.
- ▶ **1.2.8.** Put the heater in hot mode or running, on a stable level surface, in a way to prevent the risk of fire.
- ▶ **1.2.9.** Keep animals at a safe distance from the heater.
- ▶ **1.2.10.** Disconnect the heater from the mains socket when not in use.
- ▶ **1.2.11.** When it is controlled by a thermostat, the heater can switch on at any time.
- ▶ **1.2.12.** Never use the heater in frequently inhabited rooms, or in the bedroom.

- ▶ **1.2.13.** Never block the air vent (rear side) or the air outlet (front side) of the heater.
- ▶ **1.2.14.** When the heater is hot or connected to the mains electricity or functioning, it must never be moved, handled, topped-up or subject to any maintenance interventions.
- ▶ **1.2.15.** Do not duct the air entering or exiting the heater.
- ▶ **1.2.16.** Keep the hot parts of the heater at an adequate distance from inflammable or termolabile materials (including the power supply cable).
- ▶ **1.2.17.** If the power supply cable is damaged, it must be replaced by the technical after-sales centre, in order to prevent all risks.

2. UNPACKING

- ▶ **I°.** Remove all packaging materials used to wrap and deliver the heater and dispose of them in compliance with the Standards in force.
- ▶ **II°.** Extract all articles from the packaging.
- ▶ **III°.** Control for any damage undergone during transport. If the heater appears damaged, inform the dealer, where the purchase was made, immediately.

3. ASSEMBLY (29-44 kW)

(SEE FIG. 1) These models have wheels and handle/s depending on the model. These components, complete with relative nuts and bolts, are situated in the heater box.

4. FUEL

WARNING: The heater only functions with **DIESEL** or **KEROSENE**.

Only use diesel or kerosene, to prevent the risk of fire or explosion. Never use petrol, naphtha, solvents for paints, alcohol or other highly inflammable fuels.

Use non-toxic anti-freeze additives in the case of very low temperatures.

5. FUNCTIONING PRINCIPLES

(SEE FIG. 2)

A. Combustion chamber and heads, **B.** Fan, **C.** Motor, **D.** Compressor, **E.** Tank.

The compressor (**D**) started by the motor (**C**) compresses the air, which through the atomising nozzle, sucks up the fuel from the tank (**E**) due to the “**VENTURI EFFECT**”. On contact with the igniter, the atomised fuel ignites inside the combustion chamber (**A**). The combustion products are mixed with the flow of room air generated by the rotation of the fan (**B**) and pushed towards the outside of the heater. A photoresistance, connected to a circuit board, constantly checks the correct functioning of the heater, stopping the cycle in the event of anomalies.

6. FUNCTIONING

WARNING: Thoroughly read the “**INFORMATION REGARDING SAFETY**”, before switching the heater on.

IMPORTANT: Check the position of the transformer switch (220-240V / 110-120V). If the voltage set on the appliance does not correspond to that supplied by the mains, the voltage must be adapted. Loosen the two lid screw fasteners, shift the switch on to the voltage value supplied and re-mount the lid (**SEE FIG. 6**).

VERIFY THE CONGRUENCE BETWEEN POWER TENSION SUPPLY, SETTING OF DUAL VOLTAGE SWITCH AND TYPE OF PLUG, BECAUSE IMPROPER USE MAY CAUSE DAMAGE TO THE HEATER.

6.1 SWITCHING THE HEATER ON:

- ▶ **I°.** Follow all instructions relative to safety.
- ▶ **II°.** Check the presence of fuel in the tank.
- ▶ **III°.** Close the tank cap.
- ▶ **IV°.** Connect the power supply plug to the mains electricity (**SEE VOLTAGE IN “TECHNICAL DATA TABLE”**).
- ▶ **V°.** Take the “ON/OFF” switch to the “ON” (I) position (**SEE FIG. 3-4**). The heater should switch-on within a few seconds. If the heater does not start, consult the “**12. TROUBLESHOOTING**” paragraph.
- ▶ **VI°.** For the models with room thermostat, check the position of the knob (**SEE FIG. 5-9**).

N.B.: IF THE HEATER SHOULD SWITCH-OFF DUE TO THE LACK OF FUEL, TOP-UP THE TANK AND RESET THE HEATER (**SEE PAR. 6.2**).

6.2 RESETTING THE HEATER:

- ▶ *I*°. Switch the heater off and back on again (SEE FIG. 3-4).

6.3 SWITCHING THE HEATER OFF:

- ▶ *I*°. Take the "ON/OFF" switch to the "OFF" (O) position (SEE FIG. 3-4).

7. REGULATING THE PRESSURE OF THE COMPRESSOR (SEE FIG. 7)

THE COMPRESSOR PRESSURE MAY HAVE TO BE RESTORED WITH WEAR OF THE HEATER.

- ▶ *I*°. Use the "TECHNICAL DATA TABLE" to identify the correct pressure (Bar - PSI - kPa) of your heater.
- ▶ *II*°. Remove the screw/cap of the manometer connection (A).
- ▶ *III*°. Assemble the manometer (not supplied, see "ACCESSORIES").
- ▶ *IV*°. Switch the heater on.
- ▶ *V*°. Act on the regulation screw by turning it clockwise to increase the pressure and anti-clockwise to decrease it (B).
- ▶ *VI*°. Remove the manometer and restore the screw/cap (A).

8. CLEANING THE TANK FILTER

(SEE FIG. 8)

DEPENDING ON THE QUALITY OF THE FUEL THAT IS USED, THE TANK FILTER MAY HAVE TO BE CLEANED.

- ▶ *I*°. Remove the cap (A) from the tank.
- ▶ *II*°. Extract the filter (B) from the tank.
- ▶ *III*°. Clean the filter (B) with clean fuel, paying attention not to damage it.
- ▶ *IV*°. Re-mount the filter (B) in the tank.
- ▶ *V*°. Close the cap (A).

9. PRESERVATION AND TRANSPORT

IN ORDER TO KEEP AND/OR TRANSPORT THE HEATER IN THE BEST WAY, THE FOLLOWING PROCEDURE MUST BE FOLLOWED:

- ▶ *I*°. Empty the fuel tank (some models have a draining cap on the bottom of the tank. In this case, remove the drain cap and empty the fuel).
- ▶ *II*°. If the presence of residues is noted, pour clean fuel into the tank and drain off again.

- ▶ *III*°. Close the tank cap and/or the draining cap and dispose of the fuel appropriately according to the Standards in force.
- ▶ *IV*°. In order to keep the heater in the best way possible, it must be kept on a level surface to prevent the escape of fuel and in a dry place away from any possible external threats.

10. ROOM THERMOSTAT CONNECTION (...CED) (optional)

Remove the plug connected to the appliance and connect the room thermostat (optional) (SEE FIG. 9). See wiring diagram.

WARNING: BEFORE PERFORMING ANY MAINTENANCE OR REPAIRS, DISCONNECT THE POWER SUPPLY CABLE FROM THE MAINS AND MAKE SURE THAT THE HEATER IS COLD.

11. PREVENTIVE MAINTENANCE SCHEDULE

COMPONENT	MAINTENANCE FREQUENCY	MAINTENANCE PROCEDURE
Fuel tank	Empty and rinse the tank with clean fuel every 150-200 working hours	Empty and rinse the tank with clean fuel (SEE PAR. 9)
Air outlet and anti-dist filters	Clean and replace according to necessity	Contact after-sales centre
Air inlet filter	Clean or replace every 500 working hours or when necessary	Contact after-sales centre
Fuel filter	Clean or replace every 2 working seasons or when necessary	Contact after-sales centre
Igniter	Clean or replace every 1.000 working hours or when necessary	Contact after-sales centre
Fan blades	Clean and replace according to necessity	Contact after-sales centre

12. TROUBLESHOOTING

PROBLEM	POSSIBLE CAUSE	POSSIBLE SOLUTION
The heater does not start	<ol style="list-style-type: none"> 1. Heater blocked 2. Starter switch in "OFF" position (0) 3. No power supply or missing adjustment of the voltage 4. Power supply cable interrupted 5. Control card blocked 6. Incorrect setting of the room thermostat (where present) 	<ol style="list-style-type: none"> 1. Reset the heater (SEE PAR. 6.2) 2. Take the "ON/OFF" switch to the "ON" (I) position (SEE FIG. 3-4) 3a. Insert the power supply cable into the mains socket correctly 3b. Verify that the position of the dual-voltage corresponds to the mains 3c. Contact after-sales centre 4. Contact after-sales centre 5a. Reset the heater (SEE PAR. 6.2) 5b. Contact after-sales centre 6. Act on the room thermostat, taking it to a higher temperature than that of the work environment (SEE FIG. 5-9)
The motor starts but the flame is not triggered	<ol style="list-style-type: none"> 1. No fuel 2. Incorrect pump pressure 3. Igniter dirty 4. Fuel filter dirty 5. Nozzle dirty 6. Presence of foreign substances in the tank 7. Flame control device broken 	<ol style="list-style-type: none"> 1. Top-up fuel and reset the heater 2. Regulate the pressure of the compressor (SEE PAR. 7) 3. Contact after-sales centre 4. Contact after-sales centre 5. Contact after-sales centre 6. Empty and fill the tank with clean fuel (SEE PAR. 9) 7. Contact after-sales centre
The fan is blocked or turns slowly	<ol style="list-style-type: none"> 1. Pump rotor blocked 2. Motor broken 	<ol style="list-style-type: none"> 1. Contact after-sales centre 2. Contact after-sales centre

ATTENTION: ON RE-START, MAKE SURE THE GENERATOR HAS BEEN SET VIA THE RELATIVE BUTTON. (SEE PAR. 6.2)

WIRING DIAGRAMS - SCHEMI ELETTRICI

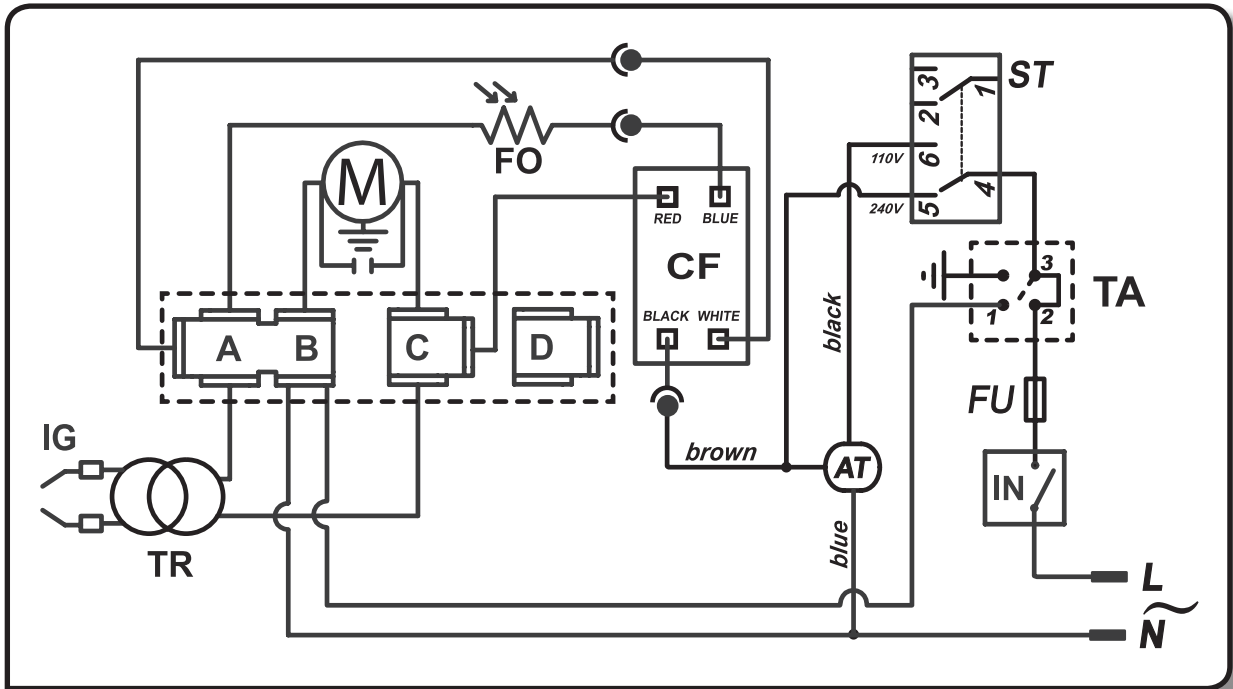

IN	Switch - Interruttore.
M	Motor - Motore.
TR	Transformer - Trasformatore.
CF	Flame Control - Controllo fiamma.
IG	Igniter - Accenditore.
FO	Photoresistance - Fotoresisteza.
FU	Fuse - Fusibile.
TA	Room thermostat - Termostato ambiente.
AT	Autotransformer - Autotrasformatore.
ST	Dual-voltage switch - Interruttore cambiatensione.
L	Line - Linea.
N	Neutral - Neutro.

ACCESSORIES - ACCESSORI

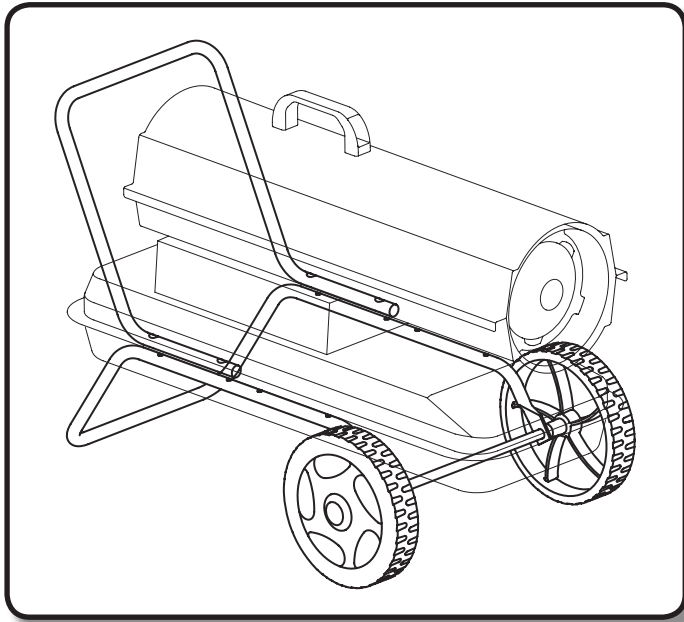

**WHEELS AND HANDLE KIT
KIT RUOTE E MANIGLIA**

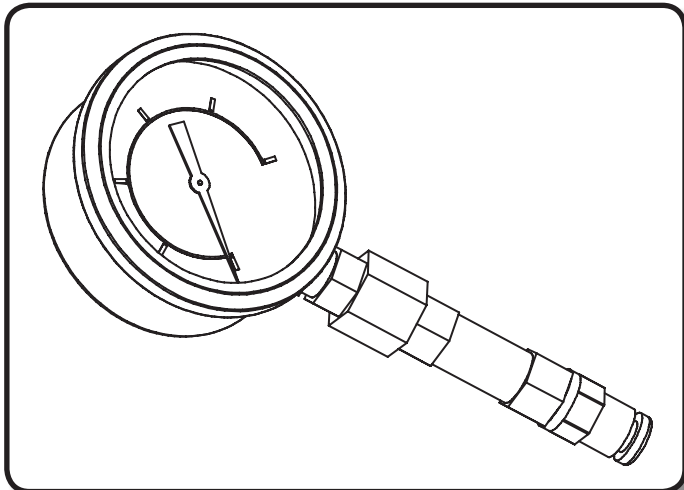



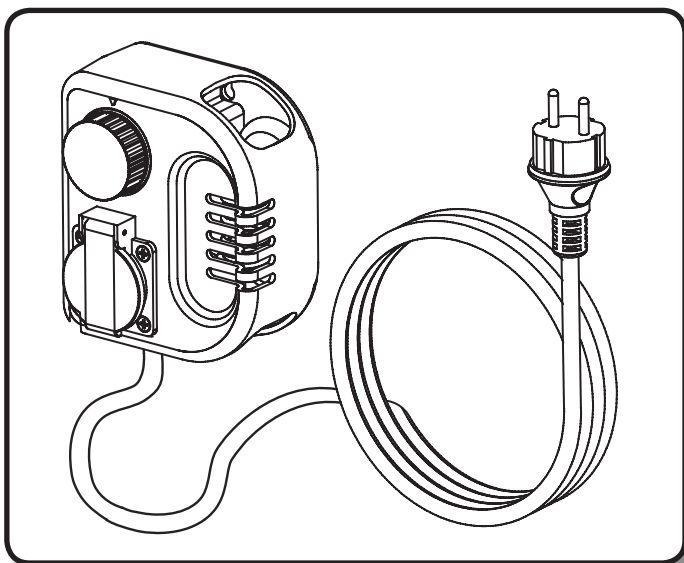





**MANOMETER
MANOMETRO**



**ROOM THERMOSTAT
TERMOSTATO AMBIENTE**

TECHNICAL DATA TABLE - TABELLA DATI TECNICI

	B 35CED DV	B 70CED DV	B 100CED DV	B 150CED DV
 MAX	10 kW-кВт 8.600 kcal/h-ккал/ч 34.200 Btu/h-БТЕ/ч	20 kW-кВт 17.200 kcal/h-ккал/ч 68.300 Btu/h-БТЕ/ч	29 kW-кВт 25.000 kcal/h-ккал/ч 99.300 Btu/h-БТЕ/ч	44 kW-кВт 37.900 kcal/h-ккал/ч 150.500 Btu/h-БТЕ/ч
	280 m³/h-м³/ч	400 m³/h-м³/ч	800 m³/h-м³/ч	900 m³/h-м³/ч
	0,8 kg/h-кг/ч	1,6 kg/h-кг/ч	2,3 kg/h-кг/ч	3,5 kg/h-кг/ч
	DIESEL-KEROSENE дизель-керосин	DIESEL-KEROSENE дизель-керосин	DIESEL-KEROSENE дизель-керосин	DIESEL-KEROSENE дизель-керосин
	15 л-л	19 л-л	44 л-л	44 л-л
	~110/240 V-B (-15%÷10%) 50 Hz-Гц 0,70/0,35 A 0,08 kW-кВт	~110/240 V-B (-15%÷10%) 50 Hz-Гц 1,6/0,8 A 0,18 kW-кВт	~110/240 V-B (-15%÷10%) 50 Hz-Гц 2/1 A 0,23 kW-кВт	~110/240 V-B (-15%÷10%) 50 Hz-Гц 2,4/1,2 A 0,28 kW-кВт
RPM	1425	2850	2850	2850
	0,20 bar-бар	0,36 bar-бар	0,27 bar-бар	0,34 bar-бар

 **IMPORTANT:** In order to have a correct function you must use an electrical generator in class G3 or more (frequency variation $\pm 1\%$, tension variation $\pm 2\%$). The maximum power of electrical generator must be three time the nominal power of device that you must connect.



CE CONFORMITY CERTIFICATE - DICHIARAZIONE DI CONFORMITÀ CE

MCS ITALY S.p.A. Via Gardesana 11, -37010- Pastrengo (VR), ITALY

Product: - Prodotto:

**B 35CED DV - B 70CED DV
B 100CED DV - B 150CED DV**

We declare that it is compliant with: - Si dichiara che è conforme a:

2014/30/EU, 2014/35/EU, 2009/125/EC

**EN 62233:2008, EN 61000-3-2:2014, EN 61000-3-3:2013, EN 55014-1:2006/
A2:2011, EN 55014-2:2015, EN 60335-1:2012/A11:2014, EN 60335-2-102:2016,
(EU) N°. 327/2011**

Pastrengo, 15/06/2017

Stefano Verani (CEO MCS Group)

► en - DISPOSAL OF THE PRODUCT

- This product has been designed and manufactured with top-quality materials and components, which can be re-cycled and re-used.
- When a crossed-wheely bin symbol is attached to the product, it means that the product is protected by the, 2012/19/UE European Directive.
- Please obtain information regarding the local differentiated collection system for electrical and electronic products.
- Respect local Standards in force and do not dispose of old products as normal domestic waste. Correct disposal of the product helps to prevent possible negative consequences for health, the environment and mankind.

► it - SMALTIMENTO DEL PRODOTTO

- Questo prodotto è stato progettato e fabbricato con materiali e componenti di alta qualità, che possono essere riciclati e riutilizzati.
- Quando ad un prodotto è attaccato il simbolo del bidone con le ruote segnato da una croce, significa che il prodotto è tutelato dalla Direttiva Europea 2012/19/UE.
- Si prega di informarsi in merito al sistema locale di raccolta differenziata per i prodotti elettrici ed elettronici.
- Rispettare le norme locali in vigore e non smaltire i prodotti vecchi nei normali rifiuti domestici. Il corretto smaltimento del prodotto aiuta ad evitare possibili conseguenze negative per la salute dell'ambiente e dell'uomo.

MCS Italy S.p.A.
Via Gardesana 11, -37010-
Pastrengo (VR), Italy
info@mcsitaly.it

MCS Central Europe Sp. z o.o.
ul. Magazynowa 5A,
62-023 Gądk, Poland
office@mcs-ce.pl

MCS Russia LLC
ul. Transportnaya - 22 ownership 2,
142802, STUPINO, Moscow region, Russia
info@mcsrussia.ru

MCS China LTD
Unit 2B, 512 Yunchuan Rd.,
Shanghai,
201906, China
office@mcs-china.cn

EURITECSA
C/Calabozos, 6 Polígono Industrial,
28108 Alcobendas (Madrid)
Spain
euritecsa@euritecsa.es

MCS Italy S.p.A.
Виа Гардесана 11, 37010
Пастренго (Верона), Италия
info@mcsitaly.it

MCS Central Europe Sp. z o.o.
ул. Магазинова, 5А,
62-023 Гадки, Польша
office@mcs-ce.pl

ООО «ЭмСиЭс Россия»
Ул. Транспортная, владение 22/2,
142802, г.Ступино, Московская обл., РФ
info@mcsrussia.ru

MCS China LTD
Юньчуань роад, 512,
строение 2В, Шанхай,
201906, Китай
office@mcs-china.cn

EURITECSA
Ц/Калабозос, 6 Полигоно Индустириал,
28108 Алкобендас (Мадрит)
Испания
euritecsa@euritecsa.es



Recycling



ENVIRONMENTAL PROTECTION: Please recycle any unwanted materials as opposed to disposing them as general waste. It is recommended the original is retained and used to store the product when not in use for prolonged periods of time. If this is not applicable ensure the materials are sorted and recycled in accordance with local regulations.



SPECIFICATION CHANGE: It is our policy to continually improve products to ensure these meet the rigours of the industry we serve. Therefore, as such we reserve the right to alter specifications, data, components & parts with-out prior notice.

WARRANTY: Please refer to the manufactures terms & conditions.

IMPORTANT: No liability will be accepted for the incorrect use of this product.

KEEP THIS BOOKLET FOR FUTURE REFERENCE

📞 Nottingham: 0115 946 1988 • London: 0208 830 3333 ✉ Nottingham: sales@hscgroupuk.co.uk • London: sean@hscgroupuk.co.uk 🌐 www.hscgroupuk.co.uk

The Hire Supply Company Terms & Conditions Apply At All Time E&OE