



PARTS DRAWING

MCE MASTER
CLIMATE SOLUTIONS

**Master 240v 48kw
Direct Oil-Fired Heater**

**Product Code:
B300CED**



Serial Number Range:

From: 09134006147

To: 11137008575

Year Of Manufacture: 2014

***Please note, when ordering online via our website if the part number is not recognised,
please Email spares@hscgroupuk.co.uk or Telephone 0115 946 1988**

KEEP THIS BOOKLET FOR FUTURE REFERENCE

Nottingham: 0115 946 1988 • London: 0208 830 3333 ✉ Nottingham: sales@hscgroupuk.co.uk • London: sean@hscgroupuk.co.uk 🌐 www.hscgroupuk.co.uk

The Hire Supply Company Terms & Conditions Apply At All Time E&OE

MODEL B 300CED

UNIT 1

ILLUSTRATED PARTS BREAKDOWN

From Serial Number: 09134006147
 Until Serial Number: 11137008575

Rev.- - Sept. 2014

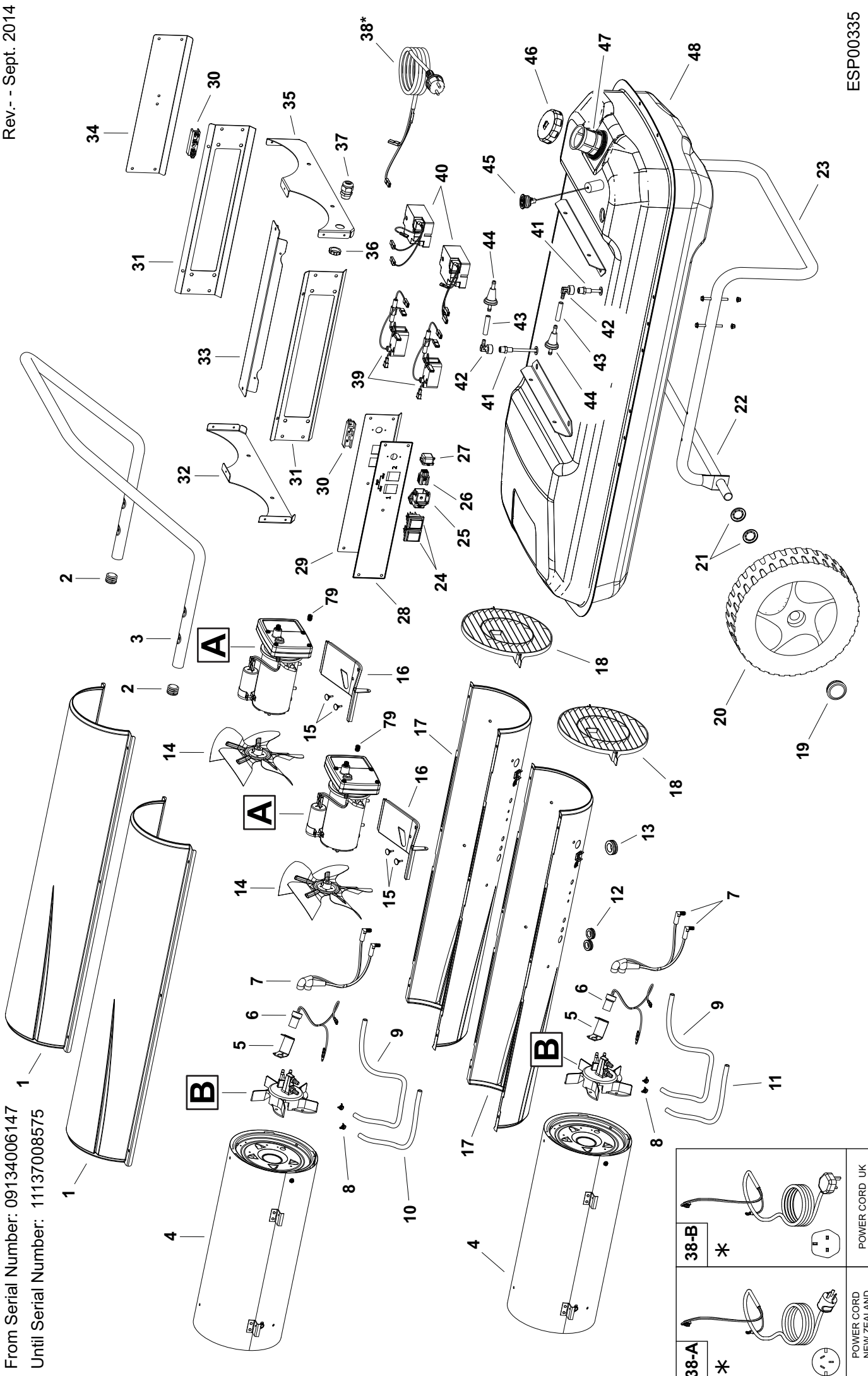

38-A	*		POWER CORD NEW ZEALAND
38-B	*		POWER CORD UK

MODEL B 300CED

UNIT 2

ILLUSTRATED PARTS BREAKDOWN

A

Motor Pump complete: 4110.463

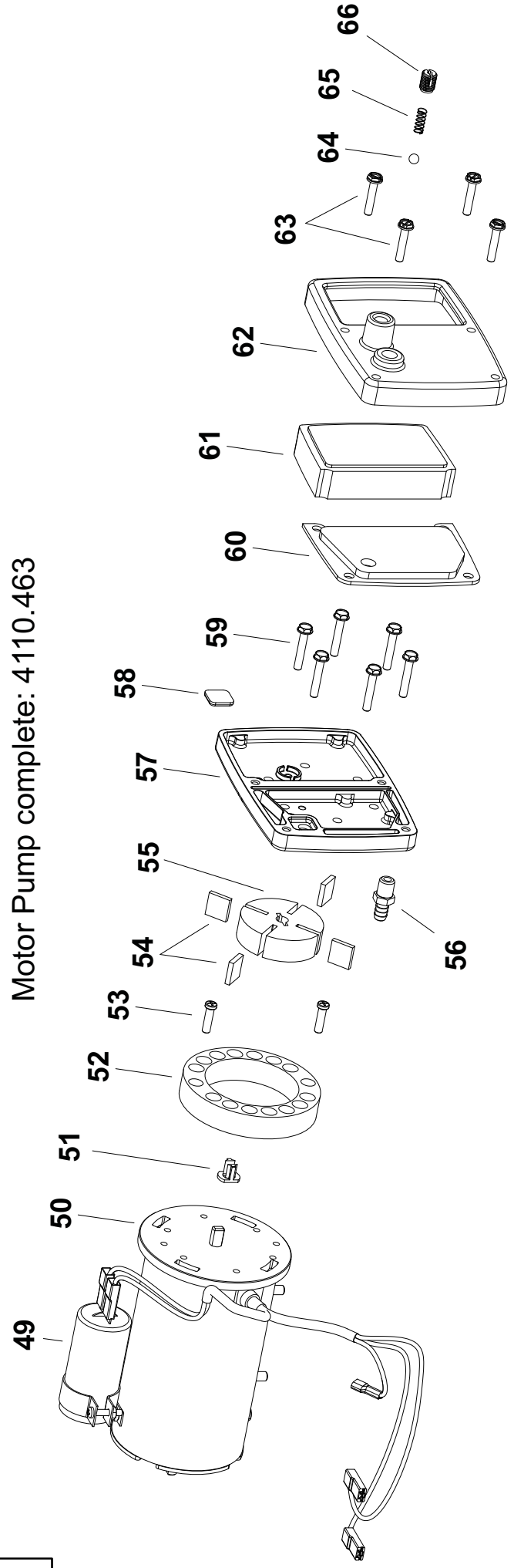

B

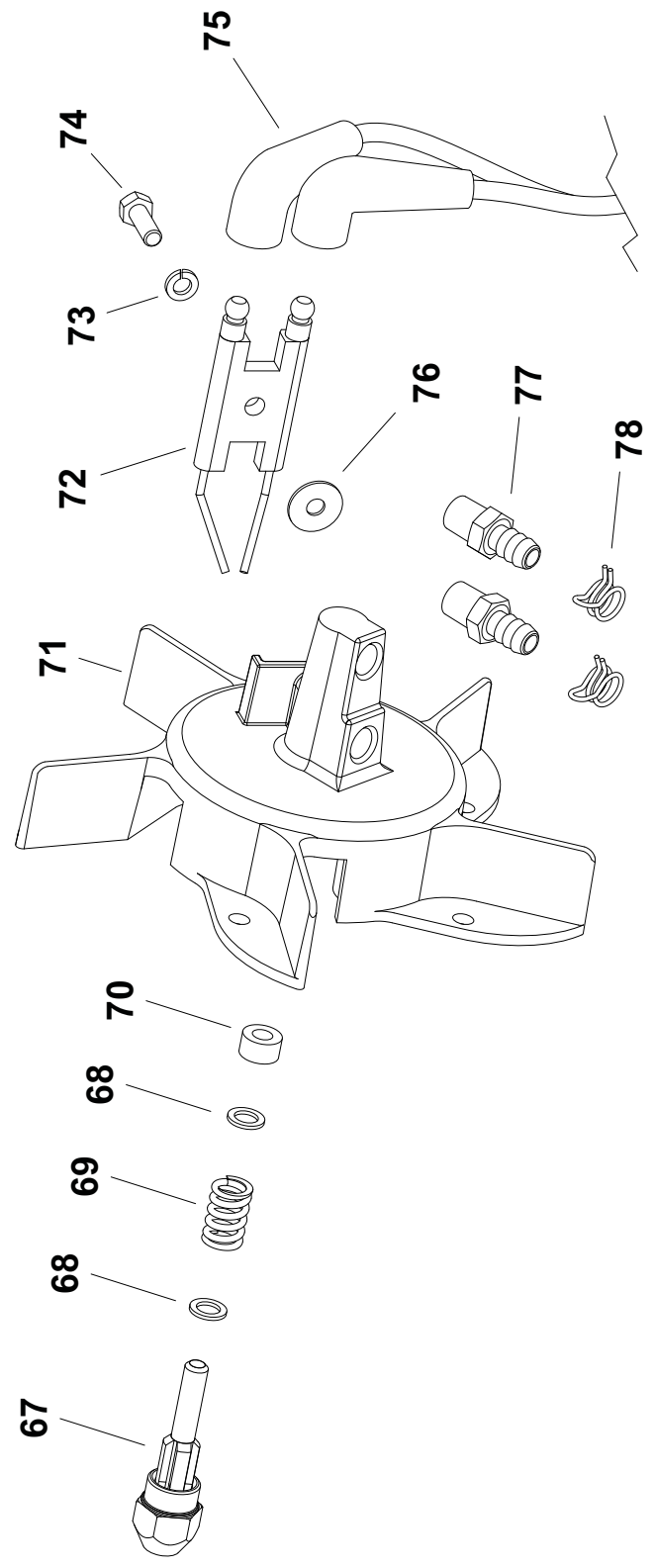

ESP00335

MODEL B 300CED

UNIT 3

PARTS LIST

Pos.	Code NR	Description	Rev. - - Sept. 2014
1	4110.360	UPPER SHELL	
2	4111.057	HANDLE PLUG	
3	4100.162	HANDLE	
4	4110.595	COMBUSTION CHAMBER	
5	4100.659	PHOTOCELL BRACKET	
6	4110.364	PHOTOCELL	
7	4111.831	HIGH TENSION WIRE	
8	4110.159	HOSE CLAMP	
9	4104.147	AIR HOSE	
10	4100.187	OIL HOSE HEATER N°1	
11	4100.189	OIL HOSE HEATER N°2	
12	4101.151	CABLE GLAND (SMALL)	
13	4160.646	CABLE GLAND (BIG)	
14	4110.415	FAN	
15	4150.553	MOTOR BUMPER	
16	4110.186	MOTOR BRACKET	
17	4111.926	LOWER SHELL	
18	4103.695	PLASTIC GRID	
19	4111.480	WHEEL PLUG	
20	4110.978	WHEEL	
21	4111.072	BLOCK WASHER	
22	4032.478	WHEELS AXLE	
23	4032.476	WHEEL SUPPORT	
24	4165.204	SWITCH	
25	4160.647	THERMOSTAT SOCKET	
26	4161.400	THERMOSTAT PLUG	
27	4162.467	THERMOSTAT CAP	
28	4100.181	CONTROL PANEL LABEL	
29	4100.179	CONTROL PANEL	
30	4106.110	TERMINAL BOX	
31	4100.176	CONTROL PANEL SUPPORT	
32	4100.168	LATERAL PANEL	
33	4100.172	INTERNAL PANEL	
34	4100.174	SIDE CONTROL PANEL	
35	4100.170	POWER CORD LATERAL PANEL	
36	4100.656	NUT	
37	4150.528	POWER CORD GLAND	
38	4033.253	POWER CORD SCHUKO (TYPE F+E)	
38-A	4033.252	POWER CORD NEW ZEALAND (TYPE I)	
38-B	4033.302	POWER CORD UK (TYPE G)	
39	4100.202	FLAME CONTROL	
40	4111.833	HIGH TENSION TRANSFORMER	
41	4100.191	SUCTION COPPER PIPE	
42	4100.192	90° CONNECTION	
43	4100.193	SUCTION HOSE	
44	4100.630	SUCTION FILTER	
45	4260.105	FUEL GAUGE	
46	4260.100	TANK CAP	
47	4290.083	TANK FILTER	
48	4100.164	TANK	

MODEL B 300CED

UNIT 4

PARTS LIST

Pos.	Code NR	Description	Rev. - - Sept. 2014
49	4111.855	CAPACITOR	
50	4111.852	MOTOR	
51	4108.635	MOTOR PUMP COUPLING	
52	4110.069	PUMP BODY	
53	4110.301	SCREW	
54	4101.666	ROTOR BLADE	
55	4103.441	ROTOR	
56	4104.118	STRAIGHT CONNECTION	
57	4110.407	ROTOR COVER	
58	4101.333	LINT FILTER	
59	4108.536	SCREW	
60	4101.341	OUTPUT FILTER	
61	4101.358	INTAKE FILTER	
62	4108.643	END COVER	
63	4108.528	SCREW	
64	4108.379	STEEL SPHERE	
65	4102.141	PRESSURE REGULATION SPRING	
66	4102.133	REGULATION SCREW	
67	4103.898	NOZZLE	
68	4100.525	WASHER	
69	4100.533	NOZZLE SPRING	
70	4101.622	NOZZLE SEAL SLEEVE	
71	4110.377	BURNER HEAD	
72	4110.337	BIFILAR ELECTRODE	
73	4110.393	ELASTIC WASHER	
74	4110.363	SCREW	
75	4111.831	HIGH TENSION CABLE	
76	4110.394	FIBER WASHER	
77	4104.118	STRAIGHT CONNECTION	
78	4110.159	HOSE CLAMP	
79	4102.125	CLOSURE SCREW	

RECOMMENDED SPARE PARTS

POS.	Code NR	Description	Rev. - - Sept. 2014
6	4110.364	PHOTOCELL	
39	4100.202	FLAME CONTROL	
40	4111.833	HIGH TENSION TRANSFORMER	
44	4100.630	SUCTION FILTER	
47	4290.083	TANK FILTER	
49	4111.855	CAPACITOR	
50	4111.852	MOTOR	
54	4101.666	ROTOR BLADE	
55	4103.441	ROTOR	
58	4101.333	LINT FILTER	
60	4101.341	OUTPUT FILTER	
61	4101.358	INTAKE FILTER	
62	4108.643	END COVER	
64	4108.379	STEEL SPHERE	
65	4102.141	PRESSURE REGULATION SPRING	
66	4102.133	REGULATION SCREW	
67	4103.898	NOZZLE	
72	4110.337	BIFILAR ELECTRODE	
75	4111.831	HIGH TENSION CABLE	
79	4102.125	CLOSURE SCREW	

ESP00335



Recycling



ENVIRONMENTAL PROTECTION: Please recycle any unwanted materials as opposed to disposing them as general waste. It is recommended the original is retained and used to store the product when not in use for prolonged periods of time. If this is not applicable ensure the materials are sorted and recycled in accordance with local regulations.



SPECIFICATION CHANGE: It is our policy to continually improve products to ensure these meet the rigours of the industry we serve. Therefore, as such we reserve the right to alter specifications, data, components & parts with-out prior notice.

WARRANTY: Please refer to the manufactures terms & conditions.

IMPORTANT: No liability will be accepted for the incorrect use of this product.

KEEP THIS BOOKLET FOR FUTURE REFERENCE

📞 Nottingham: 0115 946 1988 • London: 0208 830 3333 ✉ Nottingham: sales@hscgroupuk.co.uk • London: sean@hscgroupuk.co.uk 🌐 www.hscgroupuk.co.uk

The Hire Supply Company Terms & Conditions Apply At All Time E&OE