



USER MANUAL



CAT Pump 4DNX25GSI

**Product Code:
CAT4DNX25GSI**



Serial Number Range:

From:

To:

Year Of Manufacture:

***Please note, when ordering online via our website if the part number is not recognised, please Email spares@hscgroupuk.co.uk or Telephone 0115 946 1988**

KEEP THIS BOOKLET FOR FUTURE REFERENCE

Nottingham: 0115 946 1988 • London: 0208 830 3333 ✉ Nottingham: sales@hscgroupuk.co.uk • London: sean@hscgroupuk.co.uk 🌐 www.hscgroupuk.co.uk

The Hire Supply Company Terms & Conditions Apply At All Time E&OE

DATA SHEET

DIRECT-DRIVE PLUNGER PUMPS



Gas Models: 4DNX25GSI, 4DNX27GSI

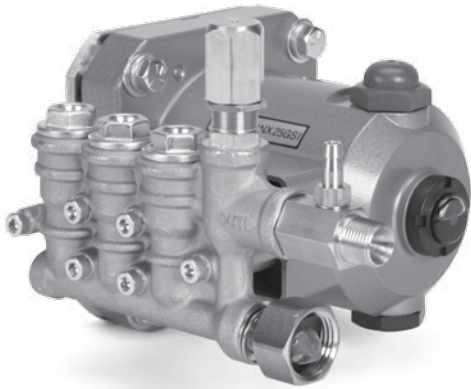

SPECIFICATIONS	U.S. Measure	Metric Measure
4DNX25GSI		
Flow	2.5 gpm	9.5 lpm
Max. Discharge Pressure	3000 psi	207 bar
Max. RPM	3450 rpm	3450 rpm
Stroke	0.268"	6.8 mm
4DNX27GSI		
Flow	2.7 gpm	10.2 lpm
Max. Discharge Pressure	3000 psi	207 bar
Max. RPM	3450 rpm	3450 rpm
Stroke	0.280"	7.2 mm

FEATURES

- Triplex plunger design provides a smooth liquid flow.
- Specially formulated high pressure seals and concentric solid ceramic plungers assure true wear surface and extended seal life.
- Stacked valve design for ease in servicing.
- Ultra-compact, hollow-shafted pump for direct mounting to gas engine.
- Integral Pressure Unloader with built-in by-pass standard on all units to assure system pressure control and pump protection.
- Fixed chemical injector standard on all units offers cleaning flexibility.
- Swivel garden hose fitting for easy inlet connection.

ELECTRIC HORSEPOWER REQUIREMENTS

MODELS	FLOW		PRESSURE					RPM
			psi 1000	psi 1200	psi 1500	psi 2000	psi 3000	
	U.S. gpm	lpm	bar 69	bar 83	bar 103	bar 138	bar 207	
4DNX25GSI	2.5	9.5	1.7	2.0	2.6	3.4	5.1	3450
4DNX27GSI	2.7	10.2	1.8	2.2	2.8	3.7	5.5	3450

$$\text{DETERMINING THE PUMP R.P.M.} \quad \frac{\text{Rated gpm}}{\text{Rated rpm}} = \frac{\text{"Desired" gpm}}{\text{"Desired" rpm}}$$

$$\text{DETERMINING THE REQUIRED H.P.} \quad \frac{\text{gpm} \times \text{psi}}{1460} = \frac{\text{Electric Brake H. P. Required}}{\text{H. P. Required}}$$

Refer to pump **Service Manual** for repair procedure and additional technical information.

COMMON SPECIFICATIONS

	U.S.	Metric
Inlet Pressure Range	Flooded to 60 psi	Flooded to 4 bar
Bore	0.551"	14 mm
Crankcase Capacity	8.5 oz.	0.25 l
Max. Liquid Temperature	140° F	60° C
Above 130°F call Cat Pumps for inlet conditions and elastomer recommendations.		
Inlet Port (1)	3/4" GHF	3/4" GHF
Accessory Port (1) (Inlet)	1/4" NPT(F)	1/4" NPT(F)
Discharge Port w/ Chemical Injector	3/8" NPT(M)	3/8" NPT(M)
Chemical Injection Hose Barb	1/4"	1/4"
Shaft Diameter (Hollow)	3/4"	19.0 mm
Weight	10.7 lbs.	4.9 kg
Dimensions	8.03 x 7.73 x 6.51"	204 x 196 x 165 mm

EXPLODED VIEW

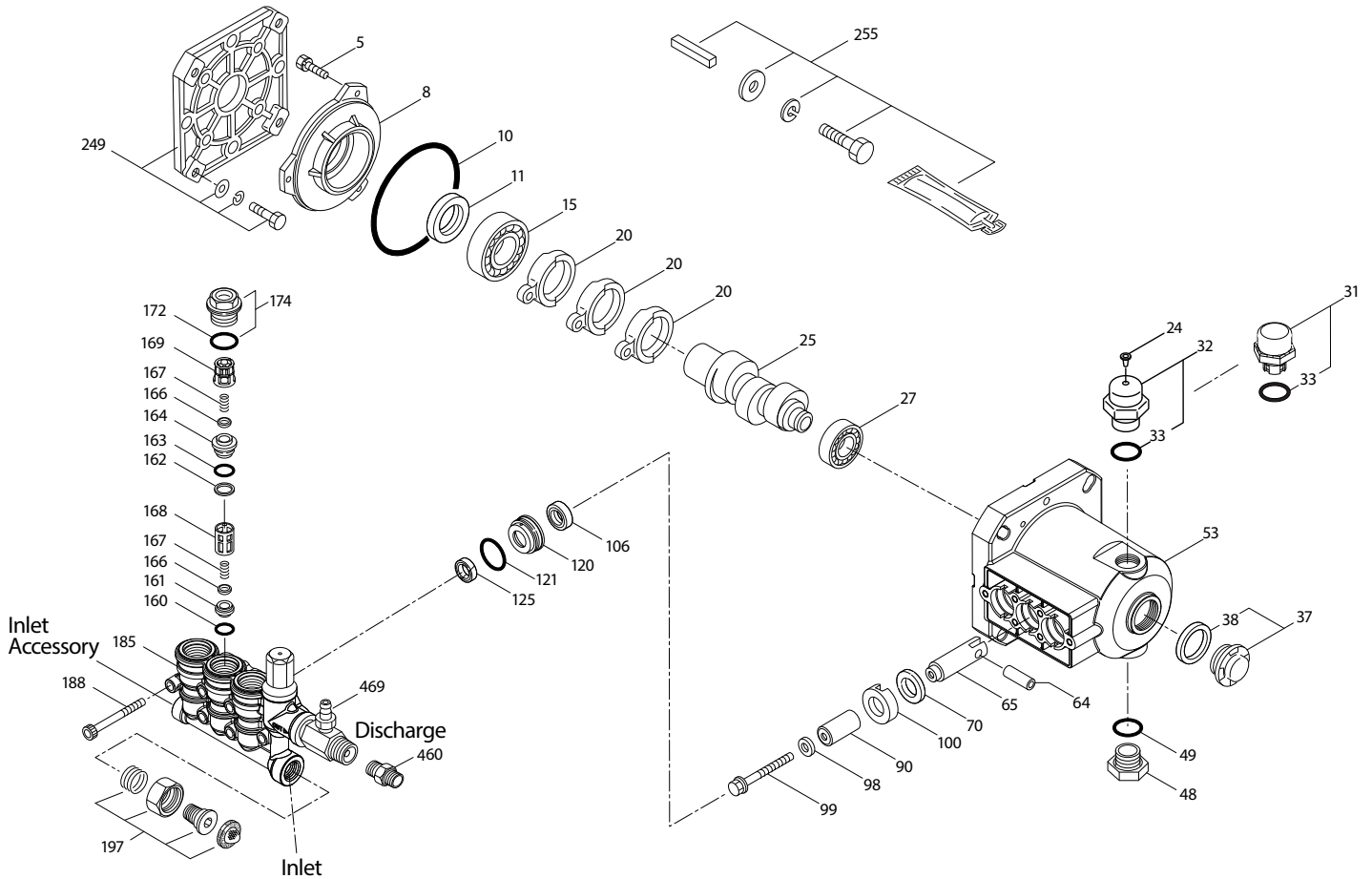

PARTS LIST

ITEM	P/N	MATL	DESCRIPTION	QTY
5	549360	STCP R	Screw, HH (M6x14)	3
8	547153	AL	Cover, Bearing	1
10	14041	NBR	O-Ring, Bearing Cover - 70D	1
11	55337	NBR	Seal, Oil - 70D	1
15	14488	STL	Bearing, Ball - Inner	1
20	547048	TNM	Rod, Connecting	3
24	549608	LDPE	Plug, Oil Cap	1
25	49883	CM	Crankshaft, 3450 RPM, 3/4", 6.8 mm (4DNX25GSI)	1
	49882	CM	Crankshaft, 3450 RPM, 3/4", 7.2 mm (4DNX27GSI)	1
27	15710	STL	Bearing, Ball	1
31	549726	—	Cap, Vented w/O-Ring (Rain Cap)	1
32	547961	RTP	Cap, Oil Filler w/O-Ring	1
33	14179	NBR	O-Ring, Oil Filler Cap - 70D	1
37	92241	—	Gauge, Bubble Oil w/Gasket	1
38	44428	NBR	Gasket, Flat Flex, Oil Gauge - 80D	1
48	44842	NY	Plug, Drain	1
49	14179	NBR	O-Ring, Drain Plug - 70D	1
53	49801	AL	Crankcase	1
64	46229	CM	Pin, Crosshead	1
65	542402	BB	Rod, Plunger	3
70	47215	NBR	Seal, Oil - 70D	3
90	547091	CC	Plunger (M14x25.5)	3
98	46730	NBR	Washer, Seal - 90D	3
99	542405	S	Retainer, Plunger (M6x35)	3
100	46233	D	Retainer, Seal	3
106	49816	NBR	Seal, LPS	3

ITEM	P/N	MATL	DESCRIPTION	QTY
120	49804	BB	Case, Seal	3
121	13976	NBR	O-Ring, Seal Case - 70D	3
125	49824	BP	Seal, HPS	3
160	17428	NBR	O-Ring, Inlet Seat - 80D	3
161	547077	S	Seat, Inlet	3
162	48361	D	Back-up Ring, Discharge Seat	3
163	43358	NBR	O-Ring, Discharge Seat - 70D	3
164	547076	S	Seat, Discharge	3
166	547098	S	Valve	6
167	46865	S	Spring	6
168	543988	PVDF	Retainer, Spring, Inlet	3
169	49764	PVDF	Retainer, Spring, Discharge	3
172	142807	NBR	O-Ring, Plug - 90D	3
174	547104	BB	Plug, Valve w/O-Ring (M20x1.5)	3
185	49763	BB	Head, Manifold w/Integral Unloader Body	1
188	549357	STCP R	Screw, HSH (M6x60)	6
197	941516	BB	Assy, GH, 3/8"	1
249	30520	—	Assy, Adapter Mount	1
255	30516	STZP R	Assy, Bolt Mount	1
283	990394	—	Kit, Oil Drain (Not Shown)	1
300	76975	NBR	Kit, Seal (Incls: 98,106,121,125)	1
310	76976	NBR	Kit, Valve (Incls: 160,161,162,163,164,166,167,168,169,172)	1
400	—	—	Unloader, Integral (See Individual Parts)	1
460	107681	BB	Fitting, Discharge [3/8" NPT(M)]	1
469	7332	BB	Injector, Chemical Fixed	1

Bold Part Numbers are unique to a particular pump model. *Italics are optional items.* [] Date of latest production change. R Components comply with RoHS Directive. View Tech Bulletins 002, 024, 036, 043, 055, 074 and 083 for additional information.

MATERIAL CODES (Not Part of Part Number): AL=Aluminum BB=Brass BP=Special Poly-Blend CC=Ceramic CM=Chrome-moly D=Acetal LDPE=Low Density Polyethylene NBR=Medium Nitrile (Buna-N) NY=Nylon PVDF=Polyvinylidene Fluoride RTP=Reinforced Composite

S=304SS STL=Steel STCP=Steel/Chrome Plated STZP=Steel/Zinc Plated TNM=Special High Strength

Note: Discard Key which may come standard with most motors and **use only the key included in this kit.**

Center raised pilot guide on the **Adapter Plate** assures proper alignment of pump and engine. Before mounting pump onto engine inspect engine for **recessed seal and bearing guide** to permit adapter to completely seat into recess and four bosses to be flush with engine face.

INTEGRAL UNLOADER

SPECIFICATIONS	U.S.	Metric
Flow	3.0 gpm	11.4 lpm
PSI Range	100 - 3000 psi	6.9 - 207 bar
Inlet Port	3/4" GHF	3/4" GHF
Discharge Port	3/8" NPT(M)	3/8" NPT(M)

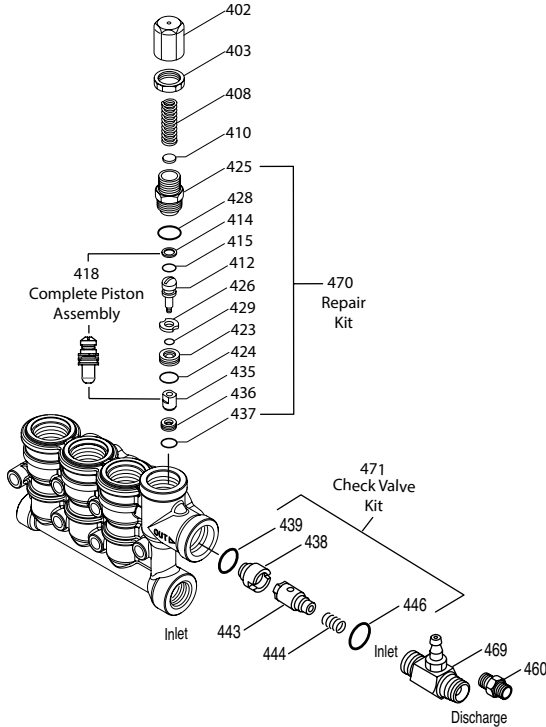

PARTS LIST

ITEM	PN	MATL	DESCRIPTION	QTY
402	547798	BB	Cap, Adjusting	1
403	45070	BB	Nut, Lock (M18 x 1)	1
408	32094	STZPR	Spring, Pressure	1
410	549352	STCPR	Retainer, Spring	1
412	45694	S	Stem, Piston	1
414	20184	PTFE	Back-up-Ring, Piston Stem	1
415	14190	NBR	O-Ring, Piston Stem - 70D	1
418	—	BB	Assy, Piston Included In Repair Kit	1
423	46249	BB	Retainer, Valve	1
424	13966	NBR	O-Ring, Valve Retainer (Outer) - 70D	1
425	547799	BB	Retainer, Piston	1
426	46250	S	Washer	1
428	26133	NBR	O-Ring, Piston Retainer - 80D	1
429	17399	NBR	O-Ring, Valve Retainer (Inner) - 80D	1
435	547800	S	Valve	1
436	49664	S	Seat	1
437	13963	NBR	O-Ring, Seat - 70D	1
438	46254	NY	Seat, Check Valve	1
439	13963	NBR	O-Ring, Check Valve Seat - 70D	1
443	49765	D	Valve, Check	1
444	45924	S	Spring	1
446	26133	NBR	O-Ring, Body - 80D	1
460	107681	BB	Fitting, Discharge [3/8" NPT(M)]	1
468	31767	NBR	Kit, O-Ring (Incls: 414, 415, 424, 428, 429, 437, 439, 446)	1
469	7332	BB	Injector, Chemical Fixed	1
470	76179	NBR	Kit, Repair (Incls: 418, 425, 428, 436, 437)	1
471	†76146	NBR	Kit, Check Valve (Incls: 438, 439, 443, 444, 446)	1

Italics are optional items. R Components comply with RoHS Directive.

† Product parts are different than repair parts.

MATERIAL CODES (Not Part of Part Number):

BB=Brass D=Acetal NBR=Medium Nitrile (Buna-N) NY=Nylon
PTFE=Pure Polytetrafluoroethylene S=304SS STCP=Steel/Chrome Plated
STZP=Steel/Zinc Plated

MODEL 7332 FIXED CHEMICAL INJECTOR

SPECIFICATIONS	U.S.	Metric
Flow	3.0 gpm	11.4 lpm
Nozzle Orifice	2.1 mm	2.1 mm
Hose Barb	1/4"	1/4"
Tapped Barb	8/32" UNF	8/32" UNF
Inlet Port	M18 x 1.0	M18 x 1.0
Discharge Port	3/8" NPT(M)	3/8" NPT(M)
Weight	5.3 oz.	0.15 kg
Dimensions	2 x 1 x 1.75"	52 x 25 x 45 mm

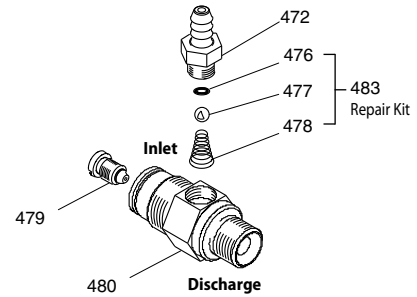

PARTS LIST

ITEM	PN	MATL	DESCRIPTION	QTY
472	49132	BB	Barb	1
476	—	NBR	O-Ring, Barb - 70D	1
477	—	S	Ball	1
478	—	S	Spring	1
479	—	S	Orifice	1
480	—	BB	Body	1
483	76176	NBR	Kit, Repair (Includes: 476, 477, 478)	1

MATERIAL CODES (Not Part of Part Number):
BB=Brass NBR=Medium Nitrile (Buna-N) S=304SS

CHEMICAL INJECTOR PERFORMANCE CHART

Orifice Size	Maximum Injecting Pressure	Maximum Chemical Draw	Pressure Drop Across Injector At System Pressure (3000 psi)
2.1 mm	250 psi	37.2 oz/min	141 psi

Optimum performance of chemical injector occurs with 35 ft. high pressure hose and a minimum 3/8" I.D. The type of hose, extended lengths, reduced I.D. and fittings may create back pressure in excess of the low pressure nozzle rating and prevent the injector from drawing chemical.
Deduct hose friction loss from above low psi nozzle. Contact Cat Pumps for assistance with other options.

CAUTION: Deduct the pressure drop shown in the performance chart from your desired system pressure to arrive at the maximum high pressure nozzle rating. This is essential to avoid over-pressurizing the pump.

UNLOADER TYPE

An integral unloader with built-in by-pass is part of the discharge manifold to provide system pressure regulation and pump protection. This pump also includes a fixed chemical injector for chemical application.

OPERATION:

Pump should be purged of air before commencing operation. Liquid must flow through the pump without discharge restriction to assure full system pressure is reached.

Install a pressure gauge close to the manifold head of the pump to assist in setting system pressure and to periodically monitor system pressure. Setting and adjusting the pressure must be done with the system turned on. Start the system with the unloader backed off to the lowest pressure setting (counterclockwise direction). Squeeze the trigger and read the pressure on the gauge at the pump. Do not read pressure at the gun or nozzle. If more pressure is desired, turn adjusting cap one quarter turn in a clockwise direction. Squeeze the trigger and read the pressure. Repeat this process until the desired system pressure is reached. Thread lock nut up to adjusting cap. **NOTE:** Pressure is not set at the factory.

SERVICE:

The unloader should be serviced on the same schedule as the seals in the pump. Refer to 4DNX Service Manual for servicing of seals and valves, torque requirements and diagnosis and maintenance chart.

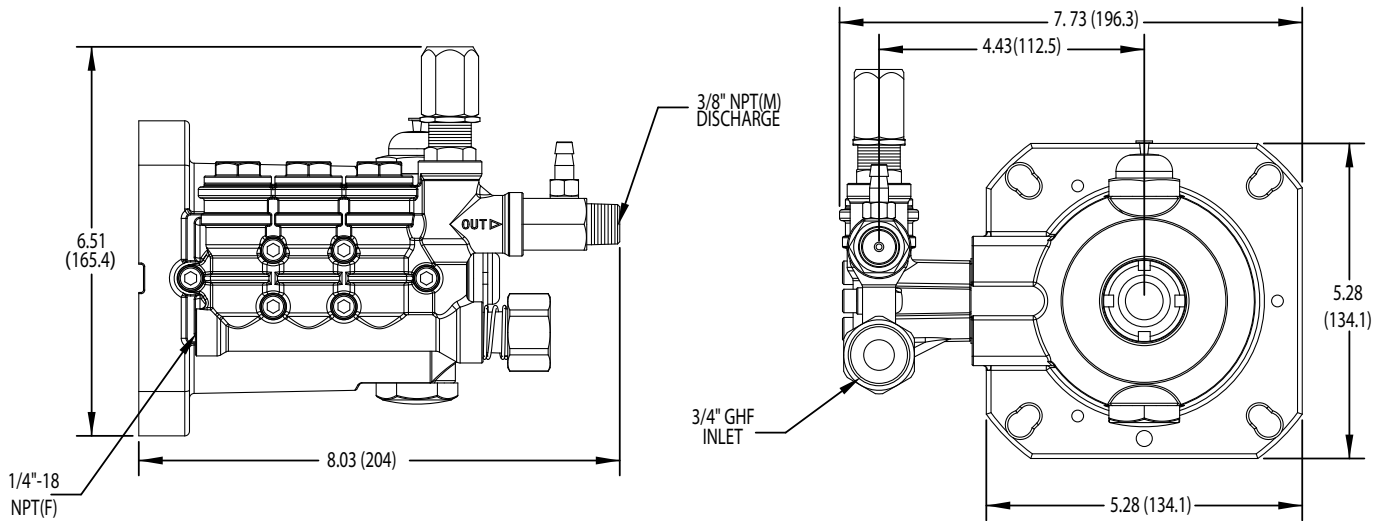

⚠ CAUTIONS AND WARNINGS

All High Pressure Systems require a primary pressure regulating device (i.e. regulator, unloader) and a secondary pressure relief device (i.e. pop-off valve, relief valve). Failure to install such relief devices could result in personal injury or damage to pump or property. Cat Pumps does not assume any liability or responsibility for the operation of a customer's high pressure system.

Read all CAUTIONS and WARNINGS before commencing service or operation of any high pressure system. The CAUTIONS and WARNINGS are included in each service manual and with each Accessory Data sheet. CAUTIONS and WARNINGS can also be viewed online at www.catpumps.com/cautions-warnings or can be requested directly from Cat Pumps.

WARRANTY

View the Limited Warranty on-line at www.catpumps.com/warranty.



CAT PUMPS

1681 - 94TH LANE N.E. MINNEAPOLIS, MN 55449-4324
 PHONE (763) 780-5440 — FAX (763) 780-2958
 e-mail: techsupport@catpumps.com
www.catpumps.com



Recycling



ENVIRONMENTAL PROTECTION: Please recycle any unwanted materials as opposed to disposing them as general waste. It is recommended the original is retained and used to store the product when not in use for prolonged periods of time. If this is not applicable ensure the materials are sorted and recycled in accordance with local regulations.



SPECIFICATION CHANGE: It is our policy to continually improve products to ensure these meet the rigours of the industry we serve. Therefore, as such we reserve the right to alter specifications, data, components & parts with-out prior notice.

WARRANTY: Please refer to the manufactures terms & conditions.

IMPORTANT: No liability will be accepted for the incorrect use of this product.

KEEP THIS BOOKLET FOR FUTURE REFERENCE

📞 Nottingham: 0115 946 1988 • London: 0208 830 3333 ✉ Nottingham: sales@hscgroupuk.co.uk • London: sean@hscgroupuk.co.uk 🌐 www.hscgroupuk.co.uk

The Hire Supply Company Terms & Conditions Apply At All Time E&OE