



PARTS DRAWING



CAT Pump 4SPX32G1I

**Product Code:
CAT4SPX32G1I**

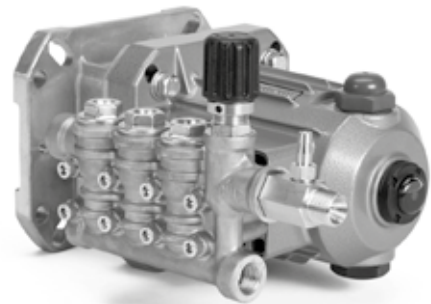

Serial Number Range:

From:

To:

Year Of Manufacture:

***Please note, when ordering online via our website if the part number is not recognised, please Email spares@hscgroupuk.co.uk or Telephone 0115 946 1988**

KEEP THIS BOOKLET FOR FUTURE REFERENCE

Nottingham: 0115 946 1988 • London: 0208 830 3333 ✉ Nottingham: sales@hscgroupuk.co.uk • London: sean@hscgroupuk.co.uk 🌐 www.hscgroupuk.co.uk

The Hire Supply Company Terms & Conditions Apply At All Time E&OE

EXPLODED VIEW

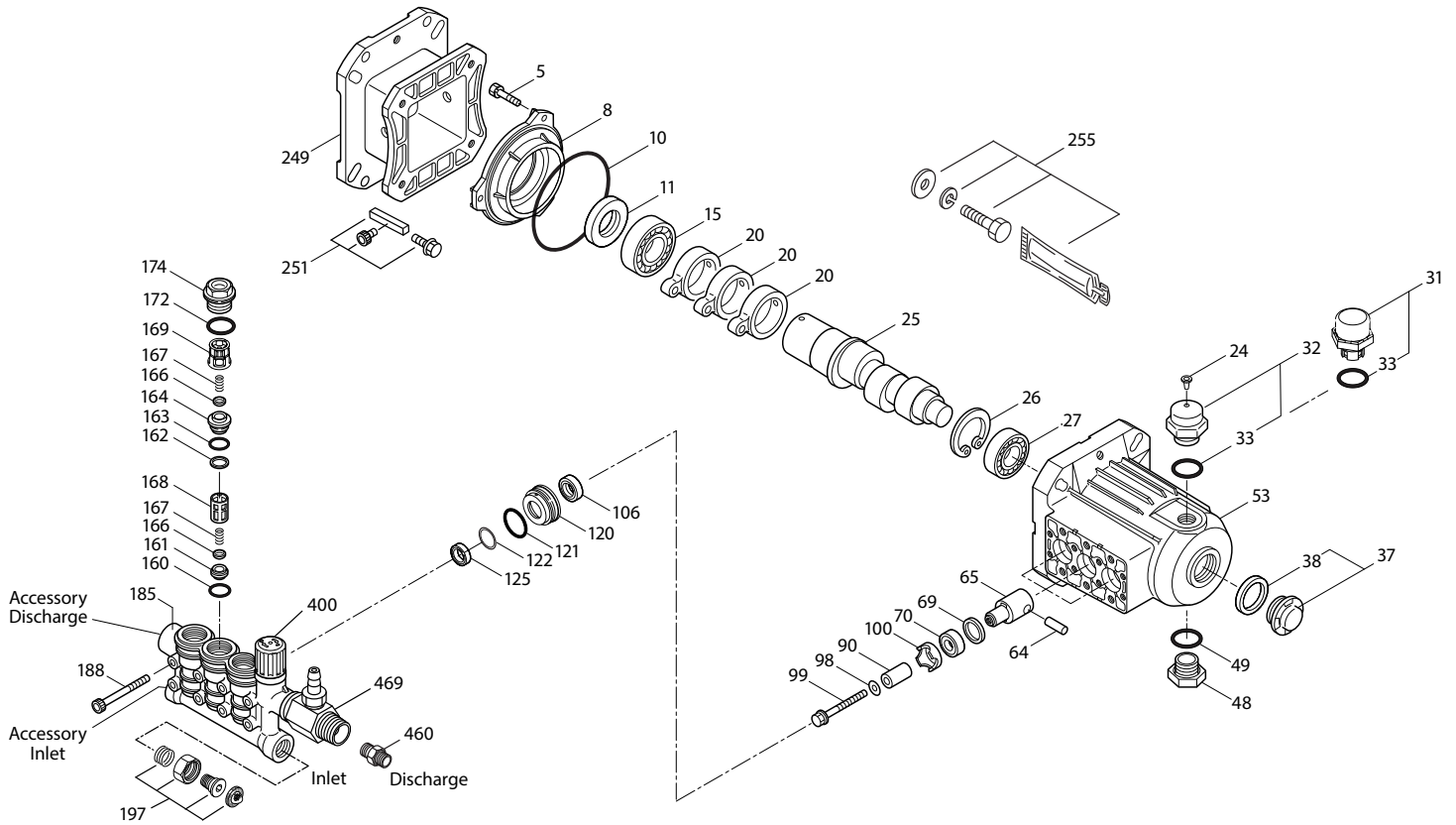

PARTS LIST

ITEM	P/N	MATL	DESCRIPTION	QTY
5	549360	STCPR	Screw, HHC Sems (M6 x 14) (See Tech Bulletin 074)	3
8	547084	AL	Cover, Bearing	1
10	14041	NBR	O-Ring, Bearing Cover-70D	1
11	125351	NBR	Seal, Oil	1
15	56110	STL	Bearing, Inner, Ball	1
20	547020	TNM	Rod, Connecting Assembly	3
24	549608	LDPE	Plug, Oil Cap	1
25	831680	FCM	Crankshaft, 3450 RPM, 1", 8.3 mm	1
26	12385	STL	Ring, Retaining	1
27	15710	STL	Bearing, Outer, Ball	1
31	549726	—	Cap, Vented with O-Ring (Rain Cap)	1
32	547961	RTP	Cap, Oil Filler with O-Ring	1
33	14179	NBR	O-Ring, Oil Filler Cap-70D	1
37	92241	PC	Gauge, Oil, Bubble with Gasket-80D (See Tech Bulletin 074)	1
38	44428	NBR	Gasket, Flat, Oil Gauge-80D	1
48	44842	NY	Plug, Drain	1
49	14179	NBR	O-Ring, Drain Plug-70D	1
53	547099	AL	Crankcase	1
64	16948	CM	Pin, Crosshead	3
65	49982	BB	Rod, Plunger	3
69	126259	STCPR	Washer, Oil Seal	3
70	25301	NBR	Seal, Oil	3
90	547091	CC	Plunger (M14 x 25.5)	3
98	46730	NBR	Washer, Seal-90D	3
99	542405	S	Retainer, Plunger (M6 x 35) (See Tech Bulletin 074)	3
100	44869	PVDF	Retainer, Seal	3
106	45188	NBR	Seal, LPS with S-Spring	3

ITEM	P/N	MATL	DESCRIPTION	QTY
120	49942	BB	Case, Seal	3
121	13977	NBR	O-Ring, Seal Case-70D	3
122	49943	PE	Ring, Support	3
125	49824	BP	Seal, HPS	3
160	17428	NBR	O-Ring, Inlet Seat-80D	3
161	547077	S	Seat, Inlet	3
162	48361	D	Backup Ring, Discharge Seat	3
163	43358	NBR	O-Ring, Discharge Seat-70D	3
164	547076	S	Seat, Discharge	3
166	547098	S	Valve	6
167	46865	S	Spring	6
168	543988	PVDF	Retainer, Spring, Inlet	3
169	49764	PVDF	Retainer, Spring, Discharge	3
172	142807	NBR	O-Ring, Valve Plug-90D	3
174	547104	BB	Plug, Valve (See Tech Bulletin 074)	3
185	49862	FBB	Head, Manifold with Integral Unloader Body	1
188	549357	STCPR	Screw, HSH (M6 x 60) (See Tech Bulletin 074)	8
197	941516	BB	Assembly, GH [$\frac{3}{8}$ " NPT(M) x $\frac{3}{4}$ " GH(F)]	1
249	—	AL	Flange, Adapter	1
251	31643	—	Mount, Adapter, Assembly (Does Not Included #249)	1
255	30514	STZP	Mount, Bolt Assembly	1
283	990394	—	Kit, Oil Drain (Not Shown)	1
300	76977	NBR	Kit, Seal (Includes: 98, 106, 121, 125)	1
310	76976	NBR	Kit, Valve (Includes: 160, 161, 162, 163, 164, 166, 167, 168, 169, 172)	1
400	—	—	Unloader, Integral (See Individual Parts)	1
460	107681	BB	Fitting, Discharge [$\frac{3}{8}$ " NPT(M)]	1
469	7332	—	Injector, Chemical Fixed	1

Italics are optional items. R Components comply with RoHS Directive.

R Components comply with RoHS Directive. For additional technical information see www.catpumps.com/literature/tech-bulletins.

MATERIAL CODES (Not Part of Part Number): AL=Aluminum BB=Brass BP=Special Poly-Blend CC=Ceramic CM=Chrome-Moly D=Acetal FBB=Forged Brass FCM=Forged Chrome-Moly LDPE=Low Density Polyethylene NBR=Medium Nitrile (Buna-N) NY=Nylon PC=Poly Carbonate PE=Polyethylene PVDF=Polyvinylidene Fluoride RTP=Reinforced Composite S=304SS STCPR=Steel/Chrome Plated STL=Steel STZP=Steel/Zinc Plated TNM=Special High Strength

Note: Discard key which may come standard with most motors and engines and **use only the key included in this kit.**

INTEGRAL UNLOADER

SPECIFICATIONS	U.S.	Metric
Flow	3.2 gpm	12.1 lpm
Pressure Range	100–3000 psi	6.9–207 bar
Discharge Port	M18 x 1.0	M18 x 1.0

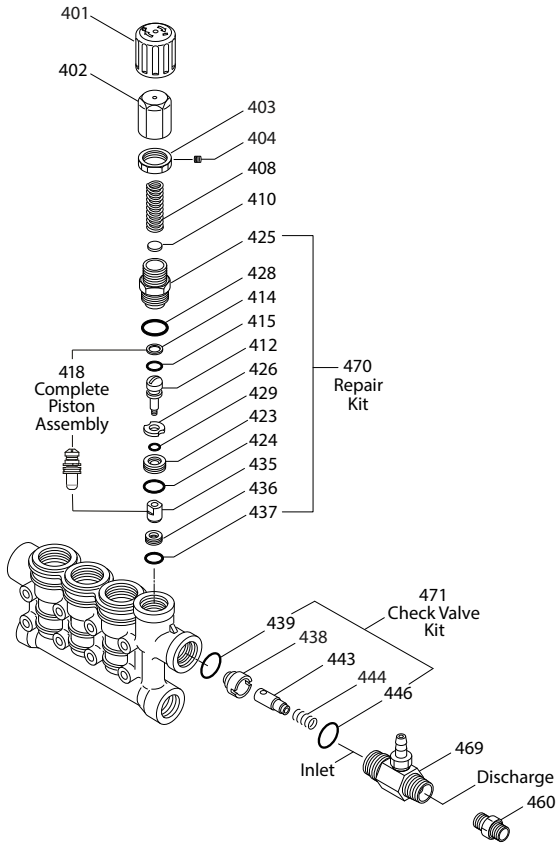

PARTS LIST

ITEM	PN	MATL	DESCRIPTION	QTY
401	547797	NY	Handle, Adjusting	1
402	547798	BB	Cap, Adjusting	1
403	548671	BB	Nut, Lock (M18 x 1)	1
404	548675	STL	Screw, Set (M4 x 1)	1
408	32094	STZP R	Spring, Pressure	1
410	549352	STCP R	Retainer, Spring	1
412	45694	S	Stem, Piston (M5)	1
414	20184	PTFE	Backup Ring, Piston Stem	1
415	14190	NBR	O-Ring, Piston Stem-70D	1
418	—	BB	Assembly, Piston, Included In Repair Kit	1
423	46249	BB	Retainer, Valve	1
424	13966	NBR	O-Ring, Valve Retainer (Outer)-70D	1
425	547799	BB	Retainer, Piston	1
426	46250	S	Washer	1
428	26133	NBR	O-Ring, Piston Retainer-80D	1
429	17399	NBR	O-Ring, Valve Retainer (Inner)-80D	1
435	547800	S	Valve/Ball Assembly	1
436	49664	S	Seat	1
437	13963	NBR	O-Ring, Injector, Fixed Chemical	1
438	46254	NY	Seat, Check Valve	1
439	13963	NBR	O-Ring Check Valve Seat-70D	1
443	49765	D	Valve, Check	1
444	45924	S	Spring, Check Valve	1
446	26133	NBR	O-Ring, Body-80D	1
460	107681	BB	Fitting, Discharge [M18 x 3/8 NPT(M)]	1
468	31767	NBR	Kit, O-Ring (Includes: 414, 415, 424, 428, 429, 437, 439, 446)	1
469	7332	BB	Injector, Fixed Chemical	1
470	76179	NBR	Kit, Repair (Includes: 418, 425, 428, 436, 437)	1
471	76146	NBR	Kit, Check Valve (Includes: 438, 439, 443, 444, 446)	1

Italics are optional items. R Components comply with RoHS Directive.

MATERIAL CODES (Not Part of Part Number): BB=Brass D=Acetal
 NBR=Medium Nitrile (Buna-N) NY=Nylon PTFE=Pure Polytetrafluoroethylene
 S=304SS STL=Steel STCP=Steel/Chrome Plated STZP=Steel/Zinc Plated

7332 FIXED CHEMICAL INJECTOR

SPECIFICATIONS	U.S.	Metric
Flow	3.2 gpm	12.1 lpm
Nozzle Orifice	2.1 mm	2.1 mm
Hose Barb	1/4"	1/4"
Inlet Port	M18 x 1.0	M18 x 1.0
Discharge Port	3/8" NPT(M)	3/8" NPT(M)
Weight	5.3 oz	0.15 kg
Dimensions	2 x 1 x 1.75"	50.8 x 25.4 x 45 mm

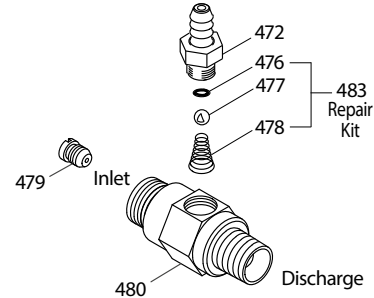

PARTS LIST

ITEM	PN	MATL	DESCRIPTION	QTY
472	49132	BB	Barb, Fix	1
476	—	NBR	O-Ring, Barb-70D	1
477	—	S	Ball	1
478	—	S	Spring	1
479	—	S	Orifice	1
480	—	BB	Body	1
483	76176	NBR	Kit, Repair (Includes: 476, 477, 478)	1

MATERIAL CODES (Not Part of Part Number):

BB=Brass NBR=Medium Nitrile (Buna-N) S=304SS

CHEMICAL INJECTOR PERFORMANCE CHART

Orifice Size	Maximum Injecting Pressure	Maximum Chemical Draw	Pressure Drop Across Injector At System Pressure (3000 psi)
2.1 mm	163 psi	35.5 oz/min	200 psi

Optimum performance of chemical injector occurs with 35 ft. high-pressure hose and a minimum 3/8" I.D. The type of hose, extended lengths, reduced I.D. and fittings may create back pressure in excess of the low-pressure nozzle rating and prevent the injector from drawing chemical. **Deduct hose friction loss from above low psi nozzle. Contact Cat Pumps for assistance with other options.**

CAUTION: Deduct the pressure drop shown in the performance chart from your desired system pressure to arrive at the maximum high-pressure nozzle rating. This is essential to avoid over-pressurizing the pump.

REGULATING DEVICE

An integral unloader with built-in bypass is part of the discharge manifold to provide system pressure regulation and pump protection. This pump also includes a fixed chemical injector for chemical application.

OPERATION:

Purge pump prior to operation by allowing liquid to flow through the pump without discharge restriction. Removing trapped air will ensure full system pressure can be obtained. Install a pressure gauge close to the manifold head to assist in setting and monitoring system pressure. Setting and adjusting the unloader pressure must be done with the system turned on. Start the system with the unloader backed off to the lowest pressure setting (counterclockwise direction). Squeeze the trigger and read the pressure on the gauge at the pump. Do not read pressure at the gun or nozzle. If more pressure is desired, release the trigger, turn adjusting cap one quarter turn in a clockwise direction. Squeeze the trigger and read the pressure. Repeat this process until the desired system pressure is reached. Thread locking nut up to adjusting cap and tighten set screw. All high-pressure systems should have a secondary relief valve. Set secondary relief valve 200–300 psi above the unloader setting. **NOTE:** Pressure is not set at the factory.

SERVICE:

The unloader should be serviced on the same schedule as the seals in the pump. Refer to 4DNX, 4DX, 4SPX Service Manual for servicing of seals and valves, torque requirements, diagnosis maintenance chart.



Recycling



ENVIRONMENTAL PROTECTION: Please recycle any unwanted materials as opposed to disposing them as general waste. It is recommended the original is retained and used to store the product when not in use for prolonged periods of time. If this is not applicable ensure the materials are sorted and recycled in accordance with local regulations.



SPECIFICATION CHANGE: It is our policy to continually improve products to ensure these meet the rigours of the industry we serve. Therefore, as such we reserve the right to alter specifications, data, components & parts with-out prior notice.

WARRANTY: Please refer to the manufactures terms & conditions.

IMPORTANT: No liability will be accepted for the incorrect use of this product.

KEEP THIS BOOKLET FOR FUTURE REFERENCE

📞 Nottingham: 0115 946 1988 • London: 0208 830 3333 ✉ Nottingham: sales@hscgroupuk.co.uk • London: sean@hscgroupuk.co.uk 🌐 www.hscgroupuk.co.uk

The Hire Supply Company Terms & Conditions Apply At All Time E&OE